

# iR SERIES



## WIRE ROPE HOIST

### FEATURES

- Compact, modular, and flexible design that is economical in use
- Fact acting, fail-safe AC/DC brakes
- Available with single and dual-speed options
- High performance gearbox with an efficient motor
- Protective rope guide
- Overload protection is a standard feature
- Electromechanical overload protection and rotary limit switch (optional)

### USPs

- Complies with FEM/ISO Classification and CE as well as ATEX Certified
- Upgradable to the Industry 4.0 platform with the Indef iQue feature
- High start-stops per hour for demanding work applications.
- Gearbox is coupled directly with the drum, and high-quality service ensures high efficiency
- High-quality, long-lasting motors for economical use with a provision for thermocouple and encoder adaptation if required by the customer

### BENEFITS

- On request, dual speed with frequency inverter allows frequency range with 1:10 speed reduction
- Adaptable design to meet customer-specific requirements for components like motors, VFDs, brakes, wire-rope etc
- Compact, low noise & maintenance, multistage, lube immersed gearbox that is directly coupled with the rope drum for high efficiency
- Better side approaches translate to better use of shed space
- Aesthetically appealing product
- Green technology IP55 enclosure-based motor design optimized for noise and vibration reduction
- Fast-action, electromagnetic disc brakes to enhance safety
- Overload protection is integrated into the hoist

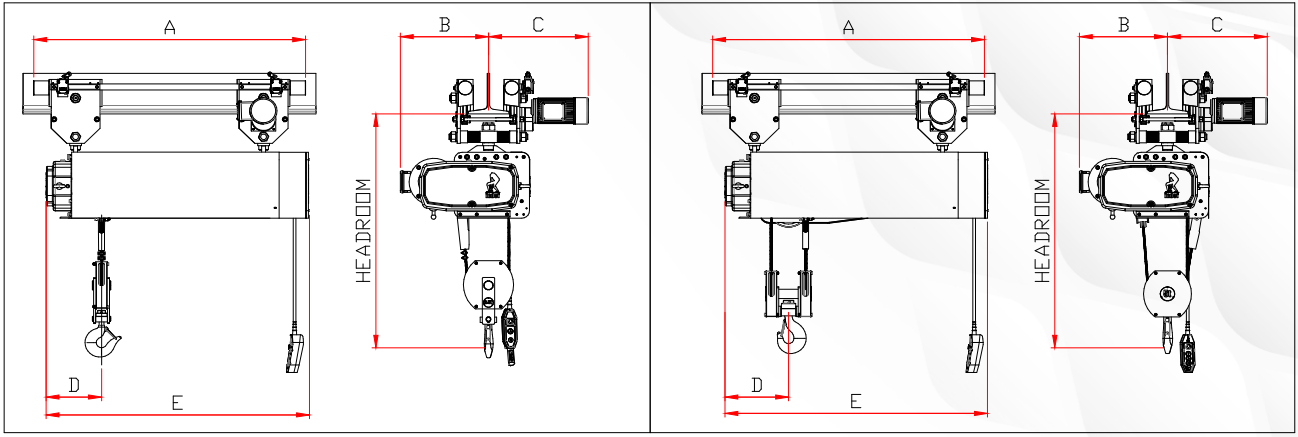

Hoist Model	Capacity ton	SWL in ton & Design Duty Class					Reeving No. of Falls	Lifting Speed MPM	Hoist Motor kW	Head Room mm	Rope Dia. mm	Monorail Beam		Cross Travel		
		FEM / ISO / IS 4 m / M 7 / Class IV	FEM / ISO / IS 3 m / M 6 / Class III	FEM / ISO / IS 2 m / M 5 / Class II	FEM / ISO / IS 1 Am / M 4 / Class I							Width Range mm	Thickness mm	Kw KW x number of motor	MPM	Wheel Dia mm
IR-010-21-BT	1	0.5	0.75	1	1.25	2	6	1.3	1150	8	90-180	20	0.37 x 1	17	140	4
IR-020-41-BT	2	0.5	1	2	2.5	4	3.0MPM - Upto 15M HOL 3.3MPM - Above 15M HOL	1.3	1150	8	90-180	20	0.37 x 1	17	140	4
IR-016-21-BT	1.6	1	1.3	1.6	2	2	7	2.5	1250	8	90-180	20	0.37 x 1	17	140	4
IR-032-41-BT	3.2	2	2.5	3.2	4	4	3.5MPM - Upto 15M HOL 4.0MPM - Above 15M HOL	2.5	1150	8	90-180	20	0.37 x 1	17	140	4
IR-020-21-BT	2	1	1.5	2	2.5	2	6	2.5	1250	10	90-180	20	0.37 x 1	17	140	4
IR-040-41-BT	4	3	3.5	4	5	4	3.0MPM - Upto 15M HOL 3.3MPM - Above 15M HOL	2.5	1150	10	90-180	20	0.37 x 1	17	140	4
IR-025-21-BT	2.5	2	2.2	2.5	3	2	8	4.1	1350	10	125-210	20	0.37 x 1	17	140	4
IR-050-41-BT	5	4	4.5	5	5.5	4	4	4.1	1250	10	125-210	20	0.37 x 1	17	140	4
IR-050-21-BT	5	4	4.5	5	5.5	2	8	8.1	1750	13	125-210	20	0.37 x 1	17	140	4
IR-100-41-BT	10	8	9	10	12.5	4	4	8.1	1650	13	125-210	20	0.37 x 2	17	140	4
IR-063-21-BT	6.3	5	5.8	6.3	6.8	2	8	10.5	1750	13	125-210	20	0.37 x 1	17	140	4
IR-125-41-BT	12.5	10	11	12.5	13	4	4	10.5	1750	13	125-210	20	0.55 x 2	17	140	8
IR-075-21-BT	7.5	6	6.5	7.5	8	2	7	10.5	2000	16	125-210	25	0.37 x 2	17	140	4
IR-150-41-BT	15	12	13	15	16	4	3.5	10.5	2000	16	125-210	25	0.55 x 2	17	140	8
IR-100-21-BT	10	8	9	10	12	2	7	14	2000	16	125-210	25	0.37 x 2	17	140	4
	20	16	18	20	24	4	3.5	14	2000	16	125-210	25	0.55 x 2	17	140	8

Hoist Model	Capacity ton	Typical GA Dimensions																Approx. Weight, Kg							
		Lift 6 m		Lift 9 m		Lift 12 m		Lift 15 m		Lift 18 m		Lift 21 m		Lift 24 m		Lift 6 m	Lift 9 m	Lift 12 m	Lift 15 m	Lift 18 m	Lift 21 m	Lift 24 m			
		A	E	A	E	A	E	A	E	A	E	A	E	A	E	B	C	D							
IR-010-21-BT	1	925	880	1075	1030	1210	1170	1365	1320	1505	1460	1665	1620	1805	1760	460	505-550	290	300	320	340	355	370	390	410
IR-020-41-BT	2	1215	1170	1505	1460	1805	1760	2115	2070	2035	1990	2255	2210	2485	2440	460	505-550	330	365	390	410	425	440	460	485
IR-016-21-BT	1.6	905	850	1025	980	1175	1130	1275	1230	1405	1360	1535	1490	1665	1620	460	505-550	290	300	320	340	355	370	390	410
IR-032-41-BT	3.2	1175	1130	1405	1360	1665	1620	2115	2070	2035	1990	2255	2210	2485	2440	460	505-550	330	365	390	410	425	440	460	485
IR-020-21-BT	2	925	880	1075	1030	1210	1170	1365	1320	1505	1460	1665	1620	1805	1760	460	505-550	290	340	360	385	400	415	435	455
IR-040-41-BT	4	1215	1170	1505	1460	1805	1760	2115	2070	2205	2160	2460	2415	2715	2670	460	505-550	330	370	395	415	430	445	465	490
IR-025-21-BT	2.5	895	875	1025	1005	1175	1155	1275	1255	1405	1385	1535	1515	1665	1645	475	525-570	270	340	360	385	400	415	435	455
IR-050-41-BT	5	1175	1155	1405	1385	1665	1645	1925	1905	2185	2165	2440	2420	2695	2675	475	525-570	350	405	435	455	475	490	410	535
IR-050-21-BT	5	1205	1240	1205	1240	1315	1350	1415	1450	1525	1570	1625	1660	1735	1770	550	535-580	440	420	445	460	480	500	520	540
IR-100-41-BT	10	1315	1350	1525	1560	1735	1770	1945	1980	2155	2180	2365	2400	2575	2610	550	535-580	550	510	550	570	595	620	650	675
IR-063-21-BT	6.3	1205	1240	1205	1240	1315	1350	1415	1450	1525	1570	1625	1660	1735	1770	550	535-580	440	610	650	665	685	710	740	780
IR-125-41-BT	12.5	1315	1350	1525	1560	1735	1770	1945	1980	2155	2180	2365	2400	2575	2610	550	535-580	550	810	850	910	975	1010	1080	1115
IR-075-21-BT	7.5	1370	1275	1370	1275	1480	1385	1555	1460	1680	1585	1755	1660	1880	1785	600	535-580	500	620	665	675	695	725	755	795
IR-150-41-BT	15	1480	1385	1680	1585	1880	1785	2080	1985	2280	2185	2480	2385	2680	2585	600	535-550	550	840	870	925	995	1060	1100	1180
IR-100-21-BT	10	1370	1275	1370	1275	1480	1385	1555	1460	1680	1585	1755	1660	1880	1785	600	535-580	500	635	685	700	720	755	780	830
	20	1480	1385	1680	1585	1880	1785	2080	1985	2280	2185	2480	2385	2680	2585	600	535-550	550	865	885	950	1050	1100	1190	1250

Note :- Above dimensions are applicable for single speed hoisting/ lowering & cross travel motions only.  
 All dimensions are in mm.  
 All dimensions are within ± 5% of specified dimensions.  
 Actual hoisting/lowering & cross travel speed is within ± 10% of specified speed.  
 Hoist with inverter speed are also available in above range.  
 Due to continuous development and improvement specification listed above can change without notice.



[www.indef.com](http://www.indef.com)



[enquire@indef.com](mailto:enquire@indef.com)



+91 (22) 489-33303

Office No. 501-504, Shelton Cubix, Plot No. 87, Sector-15, CBD-Belapur, Navi Mumbai - 400 614, India.

